

FIJI NATIONAL UNIVERSITY

COLLEGE OF ENGINEERING, SCIENCE & TECHNOLOGY

SCHOOL OF ELECTRICAL & ELECTRONIC
ENGINEERING

TRADE DIPLOMA IN ELECTRONICS ENGINEERING (INSTRUMENTATION)

STAGE 5

EEE520 –PLC & SCADA SYSTEM

SEMESTER 2 - 2016. Total [100marks] DURATION – 3 HOURS

DAY/DATE: ETT

TIME: ETT

ROOM: ETT.

INSTRUCTIONS TO STUDENTS

1. You are allowed 10 minutes Extra reading time during which you are NOT to write.
2. Begin each answer on a fresh page and use both sides of the sheet.
3. Write your candidate-number at the top of each attached sheet.
4. Insert all written sheets in their correct sequence and secure with string.
5. For all sheets of paper on which rough/draft work has been done, cross it though and you MUST ATTACH to your answer scripts.
6. Write clearly the number(s) of the question(s) attempted on the top of each sheet.
7. ANSWER ALL QUESTIONS.
8. Show all workings where necessary.
9. Do not use programmable calculators, especially the ones that does the conversions of number systems.
10. **ALWAYS CHECK YOUR WORK BEFORE YOU LEAVE THE ROOM!**

SECTION A: **Instruction:** Answer all questions.

Total (10 marks)

1. List down 5 programming rules for designing PLC coding.

(5marks)

2. What are the three elements of a PLC? Illustrate your answer with a diagram and label accordingly.

(5marks)

SECTION B: **Instruction:** Answer all questions.

Total (40 marks)

1. Define the term SCADA?

List down 3 Manufacturing Company that use this system.

(5marks)

2. Design a program that starts a timer. The timer will time for 10 seconds and then increment the counter. There are 4 motors which will come on one at a time i.e.: 1st motor at 10 sec, 2nd at 20 and so on. There should be a stop button which will de-energizers all the outputs when pressed. This circuit is for Multi – Conveyor startup system

Description	Address
Start Button	0.00
Stop Button	0.02
Motor 1	100.01
Motor 2	100.02
Motor 3	100.03
Motor 4	100.04
Timer	100.05
Counter	T0000
	00002 - 00005

(15 marks)

3. Design a program that will enable the car park attendant to monitor the car park space. Include the following:
- A sensor which detects cars entering;
 - A sensor which detects car exiting;
 - Two indicator lights – one indicating when the car park is in full capacity;
 - Another to indicate when there are space available; and
 - A reset switch for resetting the counter

(10marks)

4. The control circuit is used to detect and count the number of products being carried on an assembly line. When it counts five products, the circuit energizes a solenoid. The solenoid is energized for a period of two seconds and is then shunts off, causing it to retract

(10marks)

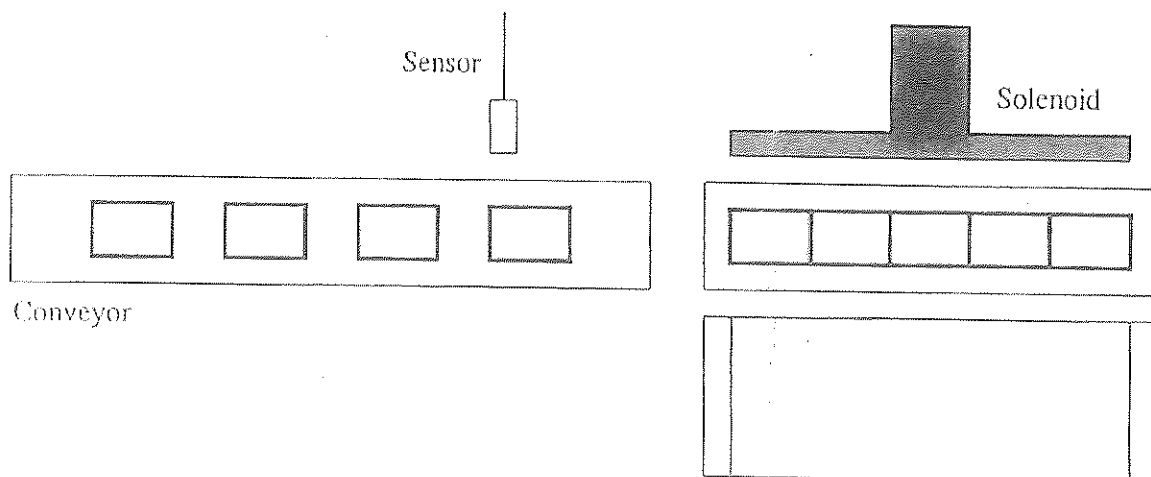

SECTION C

Instruction:

Answer all questions.

1. Design a circuit that will run the motor in forward direction when the forward push button is pressed. Also include when the reverse push button is pressed the conveyor runs in reverse direction. Lastly, interlock the auxiliary contacts to prevent the motor from being energized simultaneously. Illustrate with a hard wiring

(15 marks)

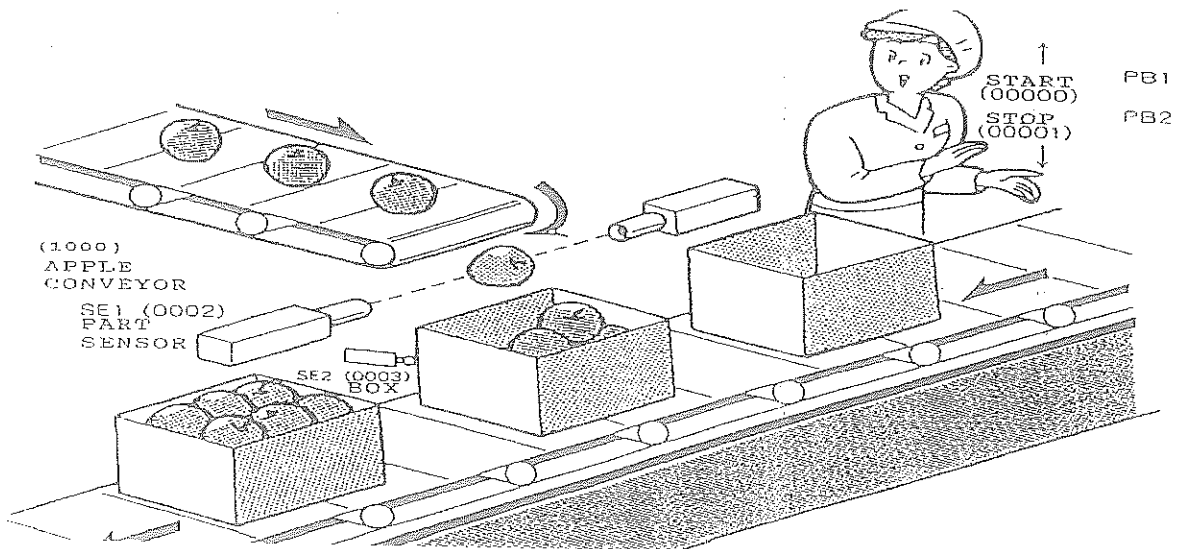

2. When PB1 (START Push Button) is pressed, the box conveyor moves. Upon detection of box present, the box conveyor stops and the Apple conveyor starts. Part sensor will count for 10 apples. Apple conveyor stops and box conveyor starts again. Counter will be reset and operation repeats until PB2 (STOP Push Button) is pressed.

QTY	Devices
0.00	START Push Button (PB1)
0.01	STOP Push Button (PB2)
0.02	Part Present (SE1)
0.03	Box Present (SE2)
QTY	Devices
100.00	Apple Conveyor
100.01	Box Conveyor

(15 marks)

3. Drilling Control Operation

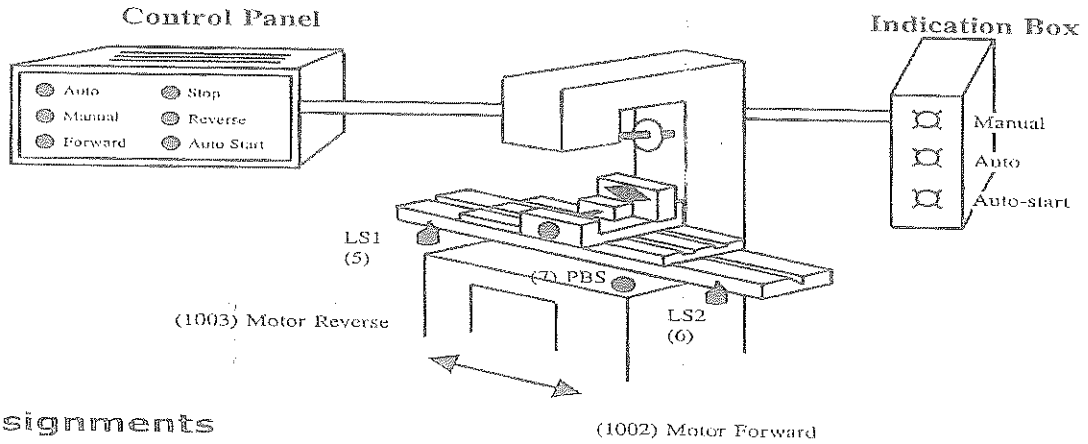

I/O Assignments

INPUT	Device	OUTPUT	DEVICE
	Auto Switch	100.03	Auto Indicator
0.00	Manual	100.00	Manual Indicator
0.01	F/Switch	100.07	Motor Forward
0.02	Stop/Switch	101.01	Motor Reverse
0.04	R/Switch	101.02	Auto Start Indicator
0.05	LS1		
0.03	LS2		
0.06	Auto start Button (PBS)		

Procedure

1. Manual Operation

- 1.1 When SW1 is ON, Motor moves forward. It can be stopped by SW2. When the drill touches LS2, the Motor is cut-off.
- 1.2 When SW3 is ON, Motor moves in reverse. It can be stopped by SW2. When the drill touches LS1, the Motor is cut-off.

2. Auto-cycle

- 2.1 When PB and LS1 is ON, the Motor moves forward until LS2 is activated. The Timer then starts timing down. The Motor reverses when the timer reaches 2 seconds. When it returns to LS1 position, the cycle is repeated.

(20 marks)

THE END